

# DISPLAY | Serve Over Counters

REFRIGERATED DISPLAY CABINETS ► SERVE OVER COUNTERS ► STATIC

## WFH 150

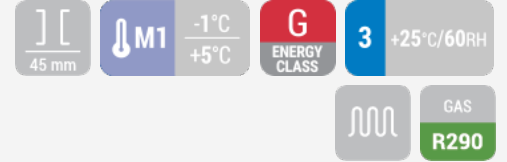

### DETAILS



### GENERAL FEATURES

- Serve-over refrigerated counter
- Ideal for display and sale of fish
- Working plate in granit
- Display area in stainless steel AISI 316
- Static Cooling
- Evaporator with anti-corrosion treatment
- Cap in curved tempered glass
- Insulated tank with water base foaming
- N.4 Adjustable feet
- Energy efficiency class: G

### TECHNICAL SPECIFICATIONS

Capacity	305 L
Temperature	M1 (-1°C-+5°C)
Consumption	8 kWh/24h
Rated Power	373 W
Noise level	63 dB(A)
Net Weight	178 Kg
Gross Weight	225 Kg
External Dimensions (WxDxH mm)	1500x1200x1180
Internal Dimensions (WxDxH mm)	1400x860x260
Packaging dimensions (WxDxH mm)	1600x1270x1130
Loading quantities 20'/40'/40'HQ	8/18/18

### CERTIFICATION

CE RoHS

### PRODUCT DIMENSIONS

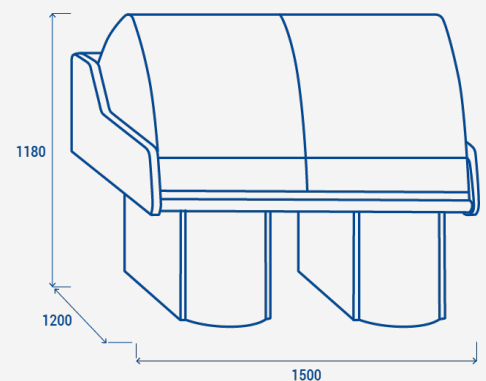

**COOL HEAD EUROPE** We make the world a cooler place

[www.coolheadeurope.com](http://www.coolheadeurope.com)